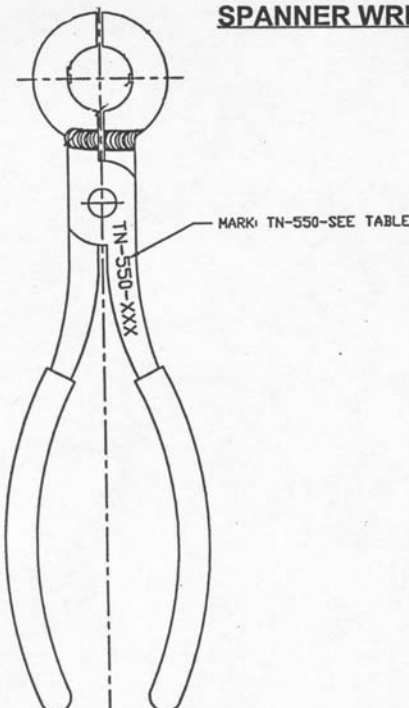
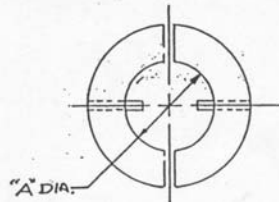

NOTE: TN-550 series tools are superseded by TN-3176 wrenches.
 TN-550 wrenches are listed here for cross-reference purposes.

REQUIRED TOOLS

SPANNER WRENCHES

TOOL No.	ø"A"
TN-550-1	.800
TN-550-2	.625
TN-550-3	.562
TN-550-4	.875
TN-550-500	.500
TN-550-562	.562
TN-550-600	.600
TN-550-625	.625
TN-550-688	.688
TN-550-800	.800
TN-550-875	.875

TORQUE WRENCH ADAPTER

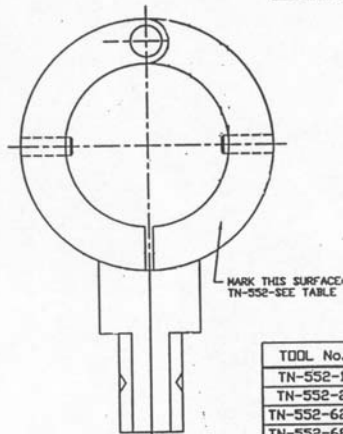

TOOL No.	ø"A"
TN-552-1	.635
TN-552-2	.810
TN-552-625	.635
TN-552-688	.698
TN-552-800	.810

NOTE: This adapter fits a "Utica" torque wrench, P/N CH150. Specify 1/4 " or 3/8" drive with #8-32 soc. set screw.