

SD48606	SYM	REVISION DESCRIPTION	DFTM	DATE	APPD	DATE
	A	RELEASED FOR PRODUCTION	J.D.B.	12/1/93	J.D.B.	12/1/93
	B	CHANGED PER CDC #23692	S.S.S.	10/11/04	J.D.B.	11/15/06

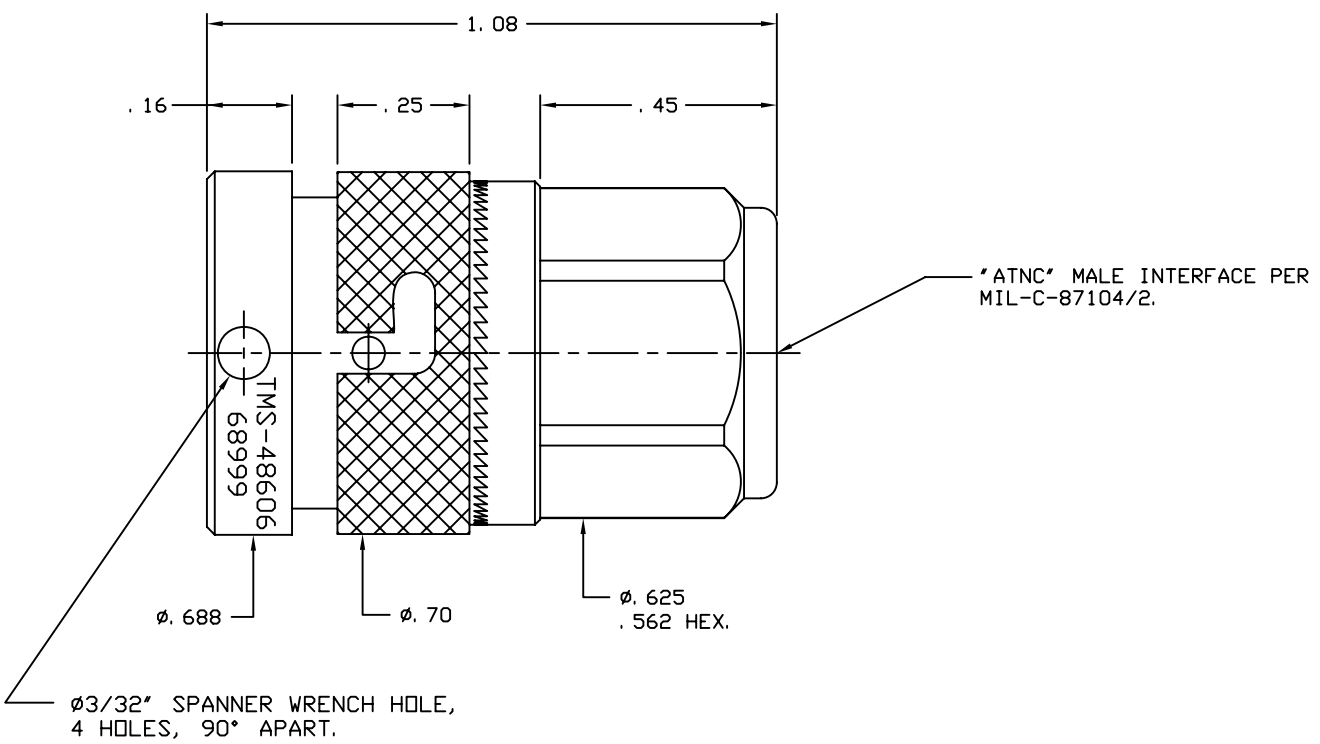

DIELECTRICS	TEFLON, ASTM D1710	NONE
COUPLING NUT	STAINLESS STEEL, ASTM A582	PASSIVATE, ASTM A380
BODY	STAINLESS STEEL, ASTM A582	PASSIVATE, ASTM A380
CONTACTS	BERYLLIUM COPPER, QQ-B-530	GOLD PLATE, MIL-G-45204
PART NAME	MATERIAL & SPEC. NUMBER	FINISH & SPEC. NUMBER

011637
W.O. NUMBER
MATERIAL:
SEE TABLE

DRAFTSMAN	John D. Bloomfield	12/1/93
CHECKER	John D. Bloomfield	12/1/93
APPROVED	John D. Bloomfield	12/1/93
UNLESS OTHERWISE SPECIFIED		
ALL DIMENSIONS ARE IN INCHES MACHINED SURFACES FINISH N/A RMS MAX. REMOVE ALL BURRS .005 MAX. BREAK MACHINE CORNERS .005 MAX. FILLET R. TOLERANCES ON DECIMALS .XX ± .03 .XXX ± .005 ANGLES ± 1° FRACTIONS ± 1/32		
DO NOT SCALE DRAWING		

TIMES MICROWAVE SYSTEMS		
TITLE: REPLACEABLE FRONT END LOCKING "ATNC" MALE		
DWG. SIZE	B	DRWG. NO. SD48606
CODE IDENT. 68999	SCALE: NONE	SHEET: 1 of 1