

Configured Cable Assemblies

Tips for designing and documenting accurate, cost effective configured cables for a drop-in fit.

Section 1 - Manufacturing

An overview of manufacturing methods used to make configured cables.

Section 2 - Documentation

Methods for concise, simple documentation of configured cable designs.

Section 3 - Routing Tips

Designing your cable routing for lower overall cost and ease of installation.

- Manual or CNC tubing benders provide a rapid, accurate, and low cost method for manufacturing configured cables.
- Following some simple design guidelines can ensure your configuration can be manufactured this way.
- Assemblies that require very tight tolerances, multiple bend radii, non circular bends, or unusual configurations can require higher cost hard tooling.

MANUFACTURING

- Produces highly accurate, repeatable configured cable assemblies without the time and expense required to develop custom hard tooling.
- Used in combination with CAD generated inspection templates.
- With a certain degree of planning, even the most demanding applications can put this manufacturing method to good use.



MANUFACTURING

Advantages

- Highest accuracy – bend fixture doubles as inspection fixture.
- Works for configurations that do not fit CNC bender.
- Can use multiple bend radii on a single cable.
- Can form cables with no straight length between bends.
- Lasts for the life of the configuration.

Disadvantages

- Increased tooling cost.
- Increased engineering time.
- Increased lead time.
- Inflexible – configuration changes require a new tool.

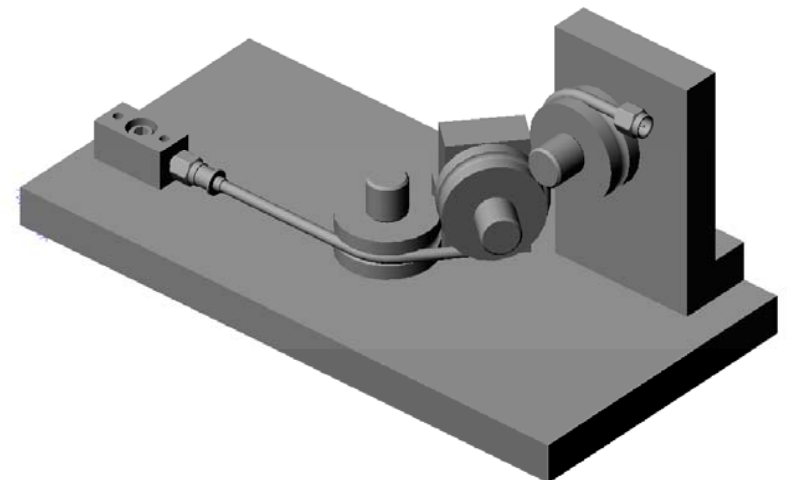

MANUFACTURING

Do

- Provide a Solidworks Drawing or a table of bend coordinates including a .stp (STEP) file.
 - AutoCAD drawings are acceptable but not preferred.
- Use a single radius size of at least 4X the cable diameter for all bends.
- Make bends lie in a principal plane of the coordinate system when practical.
- Include a straight length of at least 1 cable diameter after the connector and in-between each bend.
- Include a “Phase Adjust” section for phase matched assemblies.
- Contact an Engineer for Pre-Sale configuration design support.

Don't

- Make irregular or non-circular bends.
- Use “Coiled” sections to account for phase changes
- “Fudge” the cable configuration in a manual drawing.
- Use multiple bend radii

Bend Radius Consideration

- In general bend radii should be kept to 4X the cable diameter or larger.
- While smaller is possible, there will be a risk of causing a “wrinkle” in the bend area.
- Most wrinkles are cosmetic in nature only and will not have an effect on cable performance.



MANUFACTURING

- Cable is somewhat flexible, so light hand pressure is used for inspection purposes.
- Used for both in process and final inspection.

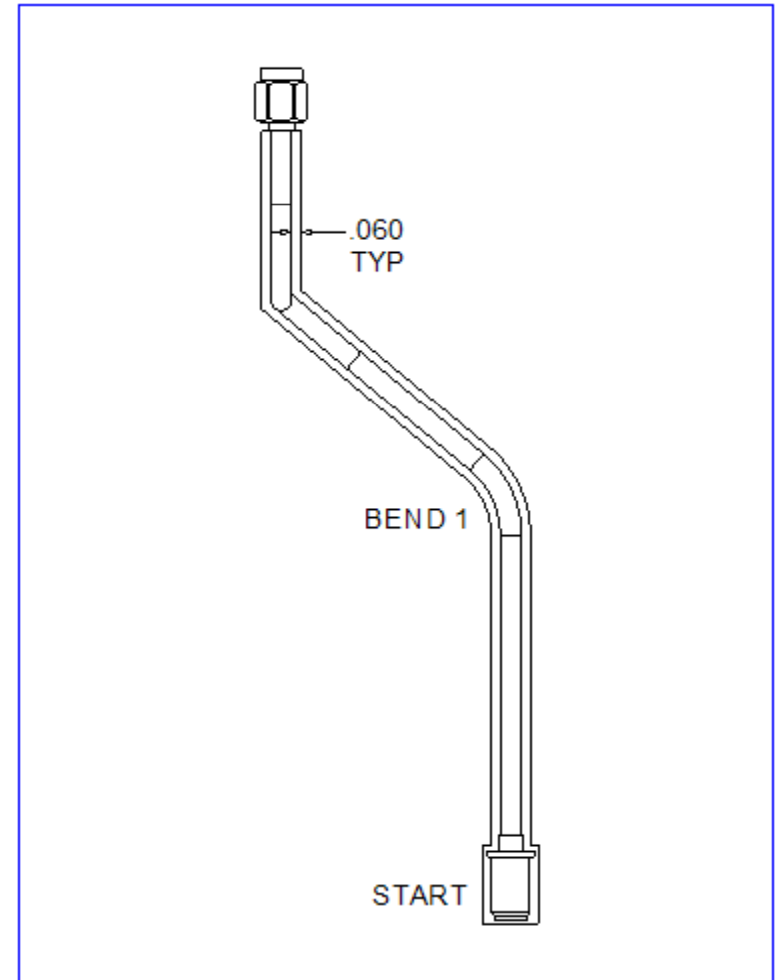

- **Bend Coordinates**
- **Tolerance Tube**
- **Drawing Notes**
- **Sample Drawing**

A configured cable can be concisely defined with minimal effort.

A bend coordinate lies at the intersection of two adjacent straight sections.

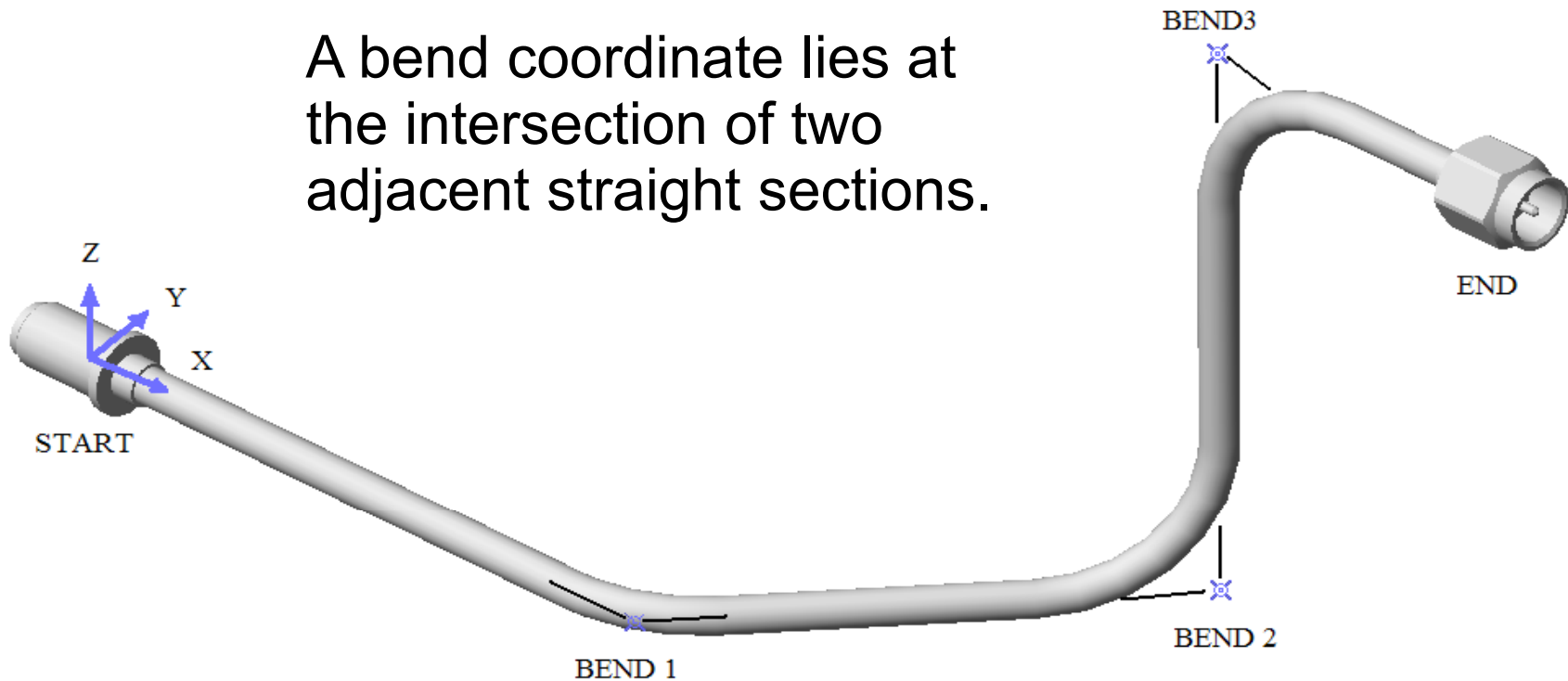

Start and end points lie at the connector electrical reference plane.

- Cable configuration can be communicated concisely via a table of bend coordinates plus a few general notes.

BEND NO	L (LENGTH)	R (ROTATION)	A (ANGLE)	BEND RADIUS	STR. LENGTH
1	11.325	0	90	.400	.520
2	9.395	90	78	.400	.209
3	8.411	270	90	.400	.125
4	6.955	180	12	.400	.437
5	2.944	90	12	.400	.682

- Formed cable tolerance is defined by a “Tolerance tube”, a specified amount larger than the cable diameter.
- Standard Tolerances:
+/- .060 for most configurations.
- Remember that cable is somewhat flexible, not stiff like rebar. Cable will flex during installation to hit clamp locations and avoid other components except on very short runs.

- As an example, if the cable diameter is .141”, the tolerance tube diameter is calculated using a .060 window as:

$$0.141 + 0.06 + 0.06 = 0.261$$

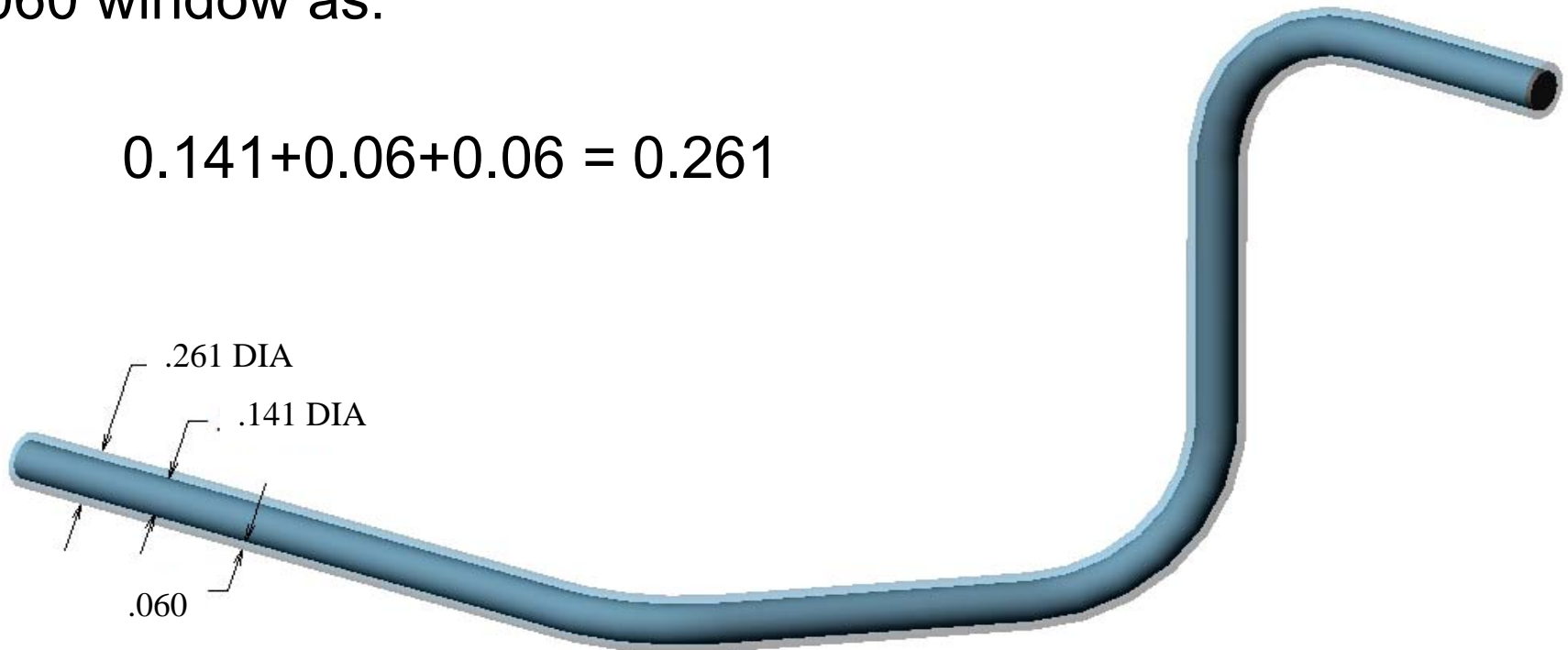

- Review your company's standard notes to eliminate any conflicts, and be sure to include the following:
 - Nominal cable size.
 - Routing tolerance.
 - Standard bend radius at cable centerline.
 - (should be at least 4x the cable diameter).
 - Connector types.
 - Nomenclature you want marked on the cable.
 - Shrink Tubing
 - Laser ID
 - Paper Tag Marking

The more we understand about your application the better we can help design a robust product...

- Frequency Range of Operation
- Maximum Insertion Loss Budget
- VSWR Expectations
- Phase Matching Requirements
- Other Environmental Considerations
 - Ambient Temperature
 - Altitude
 - Vibration
 - Etc...

DOCUMENTATION

NOTES: UNLESS OTHERWISE SPECIFIED

- CONN 1: SMAF
CONN 2: SMAM
- POINTS IN THE BEND TABLE REFER TO THE INTERSECTIONS OF STRAIGHT LINE SECTIONS ADJACENT TO EACH BEND. START AND END POINTS REFER TO THE MECHANICAL REFERENCE PLANES OF THE RESPECTIVE CONNECTORS.
- ROUTING TOLERANCE OF +/- .060 APPLIES TO ALL POSITIONS ALONG CABLE CENTERLINE.
- NOMINAL CABLE DIAMETER IS .141.
- BEND RADIUS IS .625 TO CABLE CENTERLINE FOR ALL BENDS.
- IDENTIFICATION PER MIL-C-130 OR EQUIVALENT. USE SHRINK TUBING.
- ELECTRICAL PARAMETERS:
 FREQUENCY RANGE: 2.0 TO 18GHz
 MAXIMUM VSWR: 1.50:1
 MAXIMUM INSERTION LOSS: 1.5dB
 PHASE MATCH: +/- 30 DEGREES TO REFERENCE STANDARD

LOCATION	X	Y	Z
START	0.000	0.000	0.000
BEND 1	2.560	0.000	0.000
BEND 2	3.820	1.520	0.000
BEND 3	3.820	1.520	2.220
END	5.200	1.520	2.220

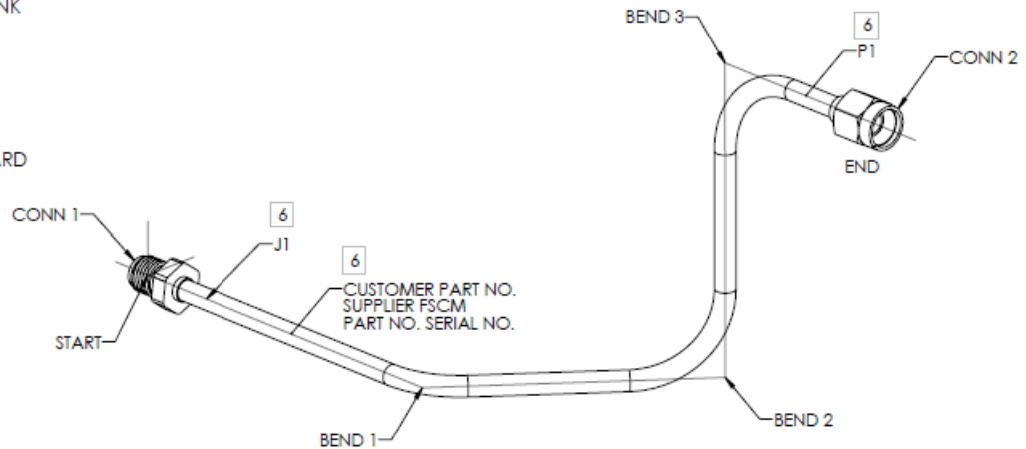

REVISIONS				
ZONE	REV	DESCRIPTION	DATE	APPROVED

	DRAWN	DRAWN				
	CHECKED					
	QA					
	MFG		SIZE A	FSCM NO.	DWG NO.	REV
	APPROVED		SCALE			SHEET

- Flex section for installation of short cables between fixed components.
- Specifying 180 degree bends.
- Using the standard radius to approximate a very large radius.
- Additional tolerance zone for phase matched cables.

ROUTING TIPS

- Very short runs of cable can be stiff. You may want to include a flex section if you are routing between fixed components.

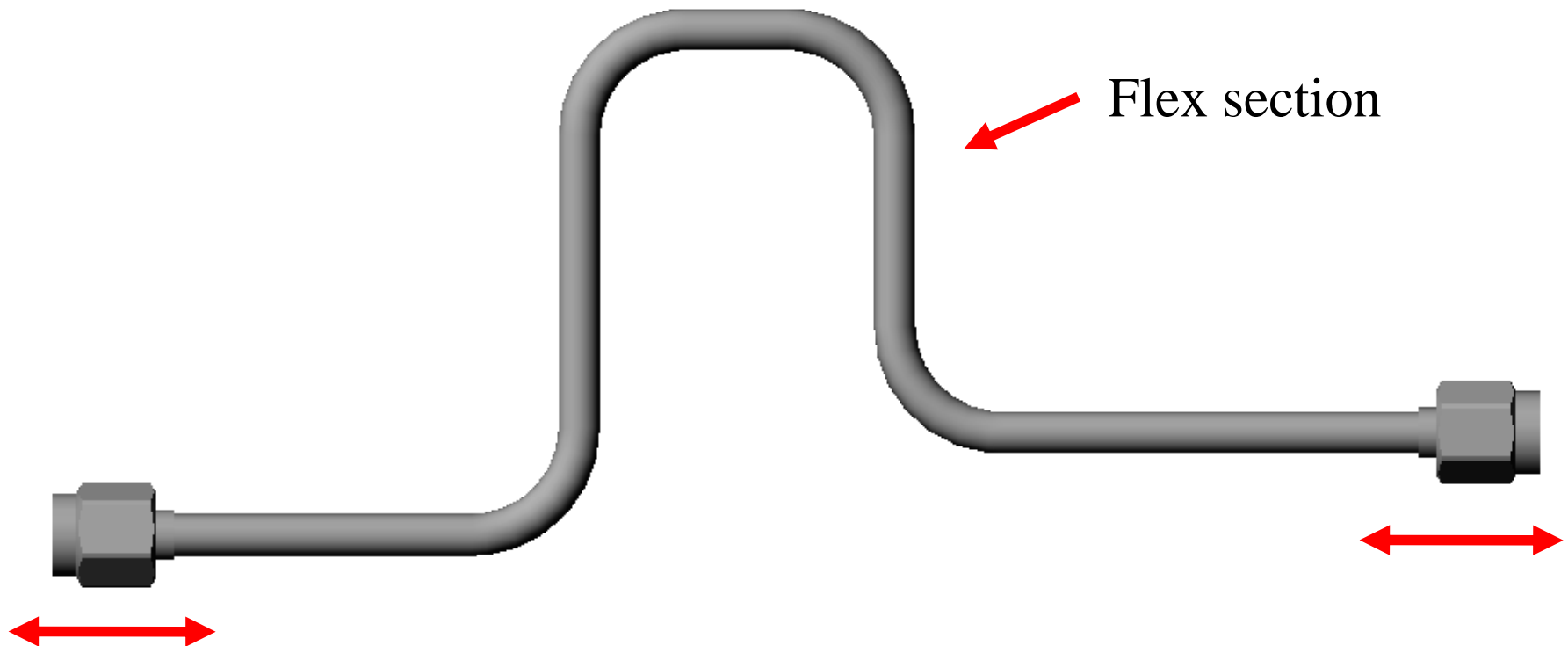

ROUTING TIPS

- Bends of 180 degrees or more can be difficult to remove from the tooling. Consider adding a straight length of at least a cable diameter between two 90 degree bends.
- If you must specify a 180 degree bend, use two bend coordinates for documentation.

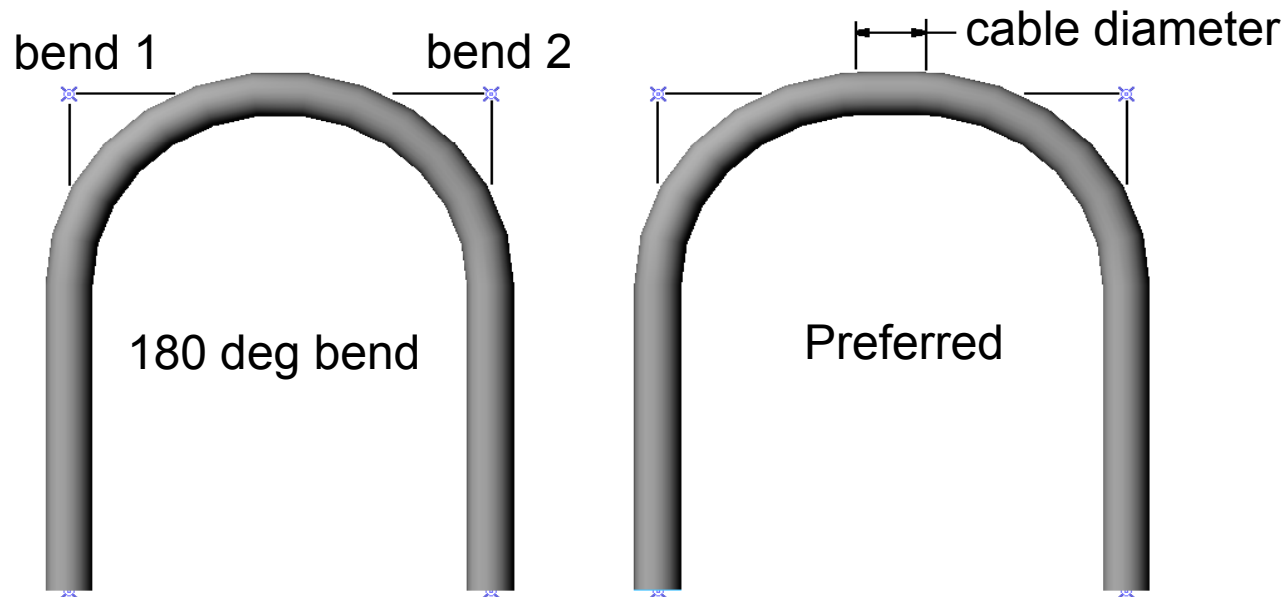

ROUTING TIPS

- Use multiple standard size bends to approximate a large radius, so your cable can be formed on the CNC bender without special tooling.

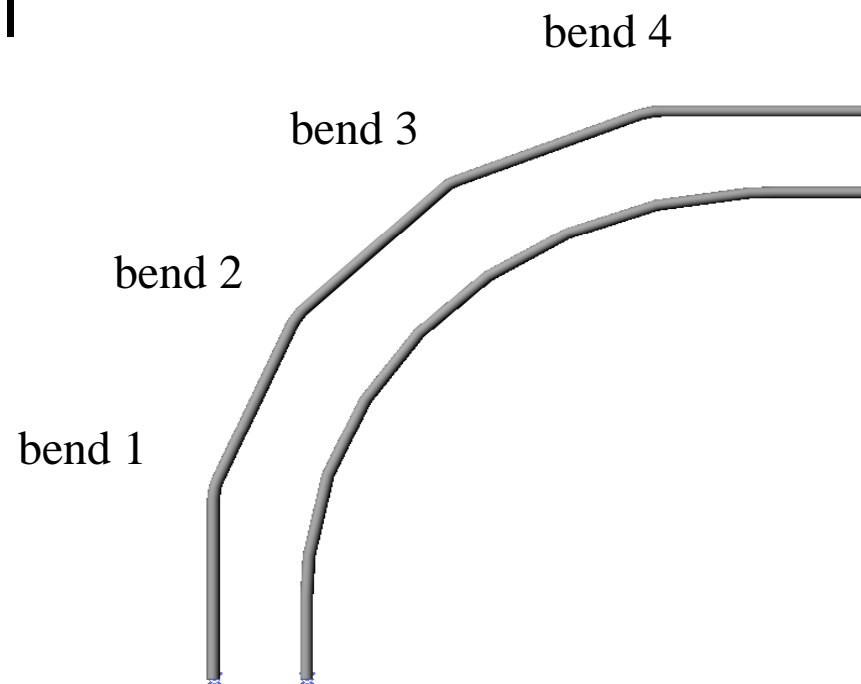

ROUTING TIPS

- Variations in cable Vg and connector components can cause variation in electrical length causing phase matched cables to require extra routing tolerances.
- **A 4% length tolerance is required for any phase matched design.**
- Additional tolerance to be used as a phase matching section should be included near the end connector of the routing.

Here is an example of a “Phase Adjust” section. Any phase matched configuration should include this type of window to allow for cable/connector variance.

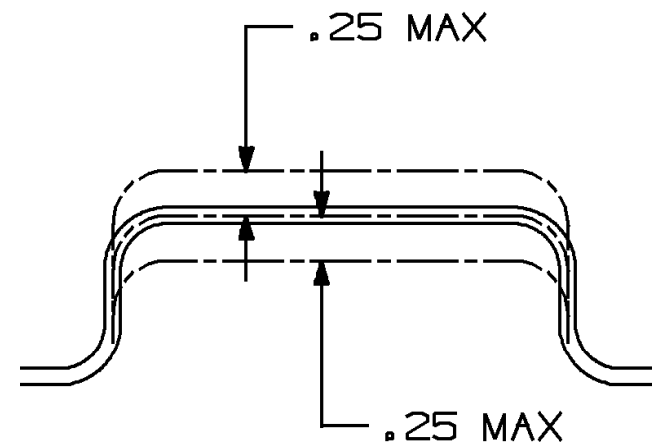

Contact your Times Regional Applications Engineer for support in designing and specifying your configured cable assemblies:

www.timesmicrowave.com/contact/technical

Phone: 203-949-8400 / 800-TMS-COAX